



2 - GENERAL DESCRIPTION AND LAYOUT

Note: Throughout this handbook all references to left-hand (L.H.) or right-hand (R.H.) are as viewed from the rear of the vehicle, looking forward.

6. The Daimler Scout Car (Figs 1 and 2) is a four wheeled drive vehicle designed for road and cross-country use. It is divided into two compartments, the crew compartment at the front with the driver on the right-hand side and the commander on the left-hand side, and the engine compartment at the rear. On early produced Mk 2 vehicles the crew compartment was provided with a folding armoured roof cover whilst on later Mk 2 and all Mk 3 vehicles this compartment is provided with a canvas roof cover (see para 22).
7. The hull is of welded construction, is bolted to the frame and suspension brackets, and the angles of the plates are such to give the maximum chance of hits glancing off instead of piercing the hull.
8. The front of the hull is fitted with two hinged lookout flaps (Fig 37(3) and (7)), one for the driver and one for the commander. The driver's flap is large to give a wide field of vision when open and when closed a limited field of vision is obtained through horizontal slots in the flap with additional protection of a safety glass screen (6). Additional flaps (1) are provided, one on each side of the hull and one at the rear for use of the driver when reversing. A gun slot with hinged doors (4) and a gun rest is provided at the front of the hull adjacent to the commander's flap.
9. A side escape door is provided at the left-hand side of the hull, adjacent to the commander's seat. This seat, when in the raised position, can be rotated to any desired position.
10. The engine compartment is provided with a single detachable cover secured by four locks, which can be readily removed to give access to the engine. An air outlet louvre is located at the rear of the engine compartment. The engine is a Daimler six cylinder liquid cooled gasoline type which develops 55 b.h.p. at a governed speed of 4,200 rev/min.
11. The engine oil tank (Fig 3(13)) and filter (14) are located on the right-hand side, and the radiator at the rear of the engine compartment. Air for cooling is drawn in by a fan, which is belt driven from the rear of the engine, and expelled through the radiator and the louvres at the rear of the vehicle.
12. Power from the engine (Fig 3(16)) is transmitted forward through a fluid coupling (19) to a pre-selective epicyclic type gearbox (20). The gearbox drives a transfer box (21) through a flexible type coupling and the transfer box incorporates a differential and a reverse gear which enables the drive in all gears to be transmitted in a forward or reverse direction of vehicle motion. The drive from the transfer box is transmitted through universal jointed propeller shafts (11) to the bevel boxes (1) which in turn drive the front and rear wheels through tracta type universal joints (3) and (24).
13. Fully independent suspension is employed at each of the road wheel stations. This is effected through suspension brackets, parallel links and concentric springs (Fig 45), each bracket having one buffer for bump and two for rebound which act against the top link.

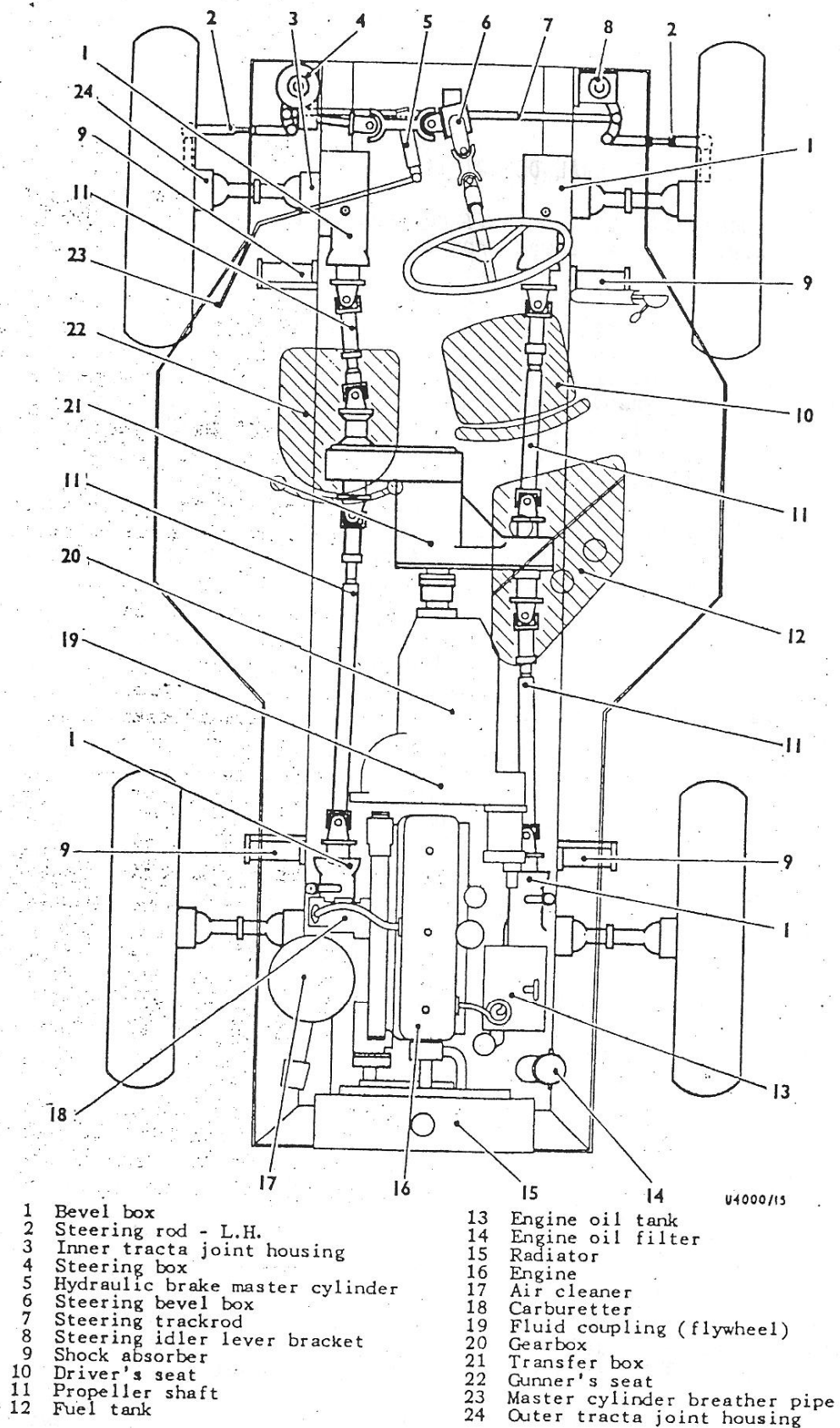

Fig 3 Layout of main components



Chap. 1 - Sect. 2
General description and layout

14. Each suspension unit is fitted with a piston type hydraulic shock absorber, mounted on a bracket attached to the frame adjacent to the suspension brackets. The lever of each shock absorber is attached through a link to the adjacent bottom suspension link.
15. The wheels are divided type, the halves being secured together by the outer ring of nuts, and the wheel secured to the hub by the inner ring of nuts.
16. The wheels are fitted with R.F. (run flat) or R.F.E. type tyres. The R.F.E. tyres are of the run flat type but are not fitted with inner tubes, therefore they cannot be punctured. The R.F. tyres are fitted with inner tubes and can be run only a limited distance after being punctured.
17. The vehicle is steered in the normal way on the two front wheels, through linkage so that the independent movement of the wheels over rough country does not affect the steering.
18. Each wheel is fitted with internal expanding brakes all of which are hydraulically operated by the foot pedal whilst the rear wheel brakes are operated through mechanical linkage by the handbrake.
19. The hydraulic system operates the brakes through a tandem type master cylinder, which consists of two master cylinders in line. Each cylinder is provided with an independent compartment in the supply tank so that one cylinder operates the brakes on the rear wheels and the other operates the brakes on the front wheels. In effect there are two separate braking systems operating, so that in the event of one system failing, the other remains effective.
20. The vehicle is fitted with an earth return 12 volt electrical system, Mk 2 vehicle having one 12 volt, 72 Ah battery and Mk 3 vehicle having two 6 volt, 110 Ah batteries.
21. On the Mk 3 vehicle the generator incorporates an electrically controlled gearbox which is included in the driving pulley and enables the generator to be driven from the engine for normal use or at an increased speed for use when the vehicle is stationary and the batteries are to be charged. It is an epicyclic type gearbox, the change-over from normal to high-speed drive being effected by means of an electro magnet with a sliding armature controlled by the driver.

Main differences between Mk 2, Mk 2 W/T and Mk 3

22. The Mk 2 and the Mk 2 W/T are the same, except that the Mk 2 is not fitted with a radio set. Mk 2 and Mk 2 W/T vehicles were originally provided with a folding armoured cover for the crew compartment instead of a canvas cover.
23. The following modifications have been incorporated in the Mk 3 vehicle:-
 - (a) The ignition distributor is sealed for waterproofing as are all the ends of the ignition high tension wiring. Ventilation pipes are fitted on the distributor and the coil and filter units are sealed.



Map. 1 - Sect. 2

General description and layout

- (b) A modified type Solex carburetter, fully waterproofed and dust-proofed, is fitted.
- (c) The charging system incorporates a two-speed generator with a control box mounted on the manifold and the control mounted behind the driver on his left-hand side. Two 6 volt batteries are fitted.
- (d) The bevel boxes driving the rear road wheels are provided with extended oil fillers.
- (e) The radiator drain tap is provided with an extended control.

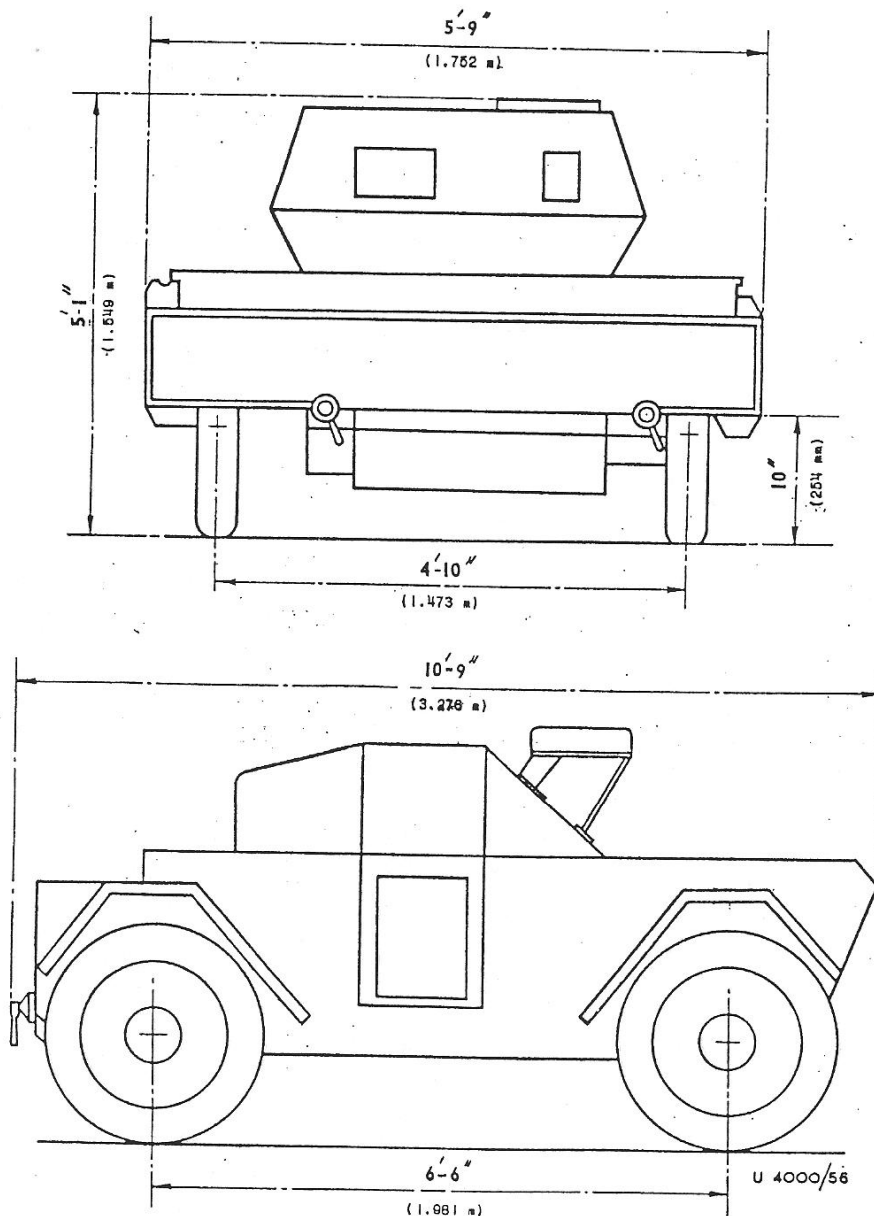

Fig 4 Vehicle dimensions



3 - DATA

DIMENSIONS - See Fig 4

WEIGHTS

Unladen	2 ton 12 cwt (5,824 lb) (2,642 kg)
Laden						
Front	1 ton 9 cwt (3,248 lb) (1,473 kg)
Rear	1 ton 14 cwt (3,808 lb) (1,727 kg)
Total	3 ton 3 cwt (7,056 lb) (3,200 kg)

BRIDGE CLASSIFICATION 5

FORDING DEPTH

Unprepared	2 ft 0 in. (0.610 m)
Prepared	5 ft 0 in. (1.524 m)

SHIPPING TONNAGE 7 ton 27 cu. ft.

ENGINE

Type	Daimler O.H.V. liquid cooled
Number of cylinders	6 in line
Maximum b.h.p. at fluid coupling	55 at 4,200 rev/min
Maximum torque at fluid coupling	105 ft lb at 1,600 rev/min
Bore	2.74 in. (69.6 mm)
Stroke	4.35 in. (110.49 mm)
Capacity	153.88 cu. in. (2,522 cc)
Compression ratio	7:1
Valve tappet clearances - temperature at 70 to 80 deg C						
Inlet and exhaust	0.015 in. (0.381 mm)
Distributor	Lucas DCH6A, BS40
						OR
Distributor	Lucas DXLH6A, BS40
Contact breaker gap	0.010-0.012 in. (0.254-0.305 mm)
Speed limiter	
Ignition timing	8 deg B.T.D.C.
For details of automatic advance - see para						
Ignition coil	Lucas BRS12, T.45-1
						OR
Ignition coil	Lucas BW12, L-0
Firing order	1 - 5 - 3 - 6 - 2 - 4
Sparking plugs	14 mm, S.R.14
Gap	0.015-0.018 in. (0.381-0.457 mm)

ENGINE LUBRICATION SYSTEM

Type of system	Dry sump
Oil pump	Gear type
Oil pressure at which warning light operates	8-10 lb/sq in. (0.562-0.703 kg/sq cm)
Oil pressure - normal	40 lb/sq in. (2.812 kg/sq cm)
Oil filter	Full-flow type



Chap. 1 - Sect. 3
 Data

COOLING SYSTEM

Radiator	Gilled tube
Fan	6-blade 16 $\frac{1}{4}$ in. dia (412.75 mm)
Circulation	Pump
Cooling control	Thermostat
Pressure relief valve	Operating - 3 to 5 lb/sq in. (0.211-0.351 kg/sq cm)

FUEL SYSTEM

Fuel pump	Mechanical diaphragm type
Carburettor	Solex type 40 WNHP0 or 30 ZNHP0
Choke	30 mm
Main jet	160
Fuel filter	Zenith, Mk 1A

ENGINE COUPLING

... Fluid type

GEARBOX

Type	Semi-automatic pre-selective - five forward gears
------	-----	-----	-----	-----	---

GEARBOX RATIOS

1st	5.36 : 1
2nd	4.08 : 1
3rd	2.32 : 1
4th	1.56 : 1
5th	1.00 : 1

TRANSFER BOX

Type	Helical and spur gears incorporating a differential. One forward and one reverse gear
------	-----	-----	-----	-----	---

Ratios

Forward gear	1.16 : 1
Reverse gear	1.36 : 1

BEVEL BOXES

Type	Bevel crown wheel and pinion
Ratio	5.50 : 1

OVERALL RATIOS - engine to road wheels

	Forward	Reverse
1st	34.50 : 1	40.10 : 1
2nd	26.30 : 1	30.50 : 1
3rd	14.95 : 1	17.34 : 1
4th	10.05 : 1	11.66 : 1
5th	6.44 : 1	7.48 : 1

MAXIMUM SPEEDS

1st	11 mile/h	(17.70 Km.p.h.)
2nd	15 mile/h	(24.14 Km.p.h.)
3rd	26 mile/h	(41.84 Km.p.h.)
4th	39 mile/h	(62.76 Km.p.h.)
5th	60 mile/h	(96.55 Km.p.h.)



PERFORMANCE

Maximum speed on road - engine speed 4,200 rev/min	60 mile/h	(96.55 Km.p.h)
Average maximum safe road speed	45 mile/h	(72.41 Km.p.h)
Range of operation - road	200 miles approx.	(321.86 Km.)
Fuel consumption - road	11.25 mile/gal	(3.98 Km./litre)
Fuel consumption - cross country	4.45 mile/gal	(1.57 Km./litre)

TURNING CIRCLE

Left lock	38 ft.	(11.58 m)
Right lock	38 ft.	(11.58 m)

NETT POWER/GROSS WEIGHT RATIO

17.46 b.h.p. per ton

MAXIMUM TRACTIVE EFFORT

100% efficiency nett	
5th gear	166 lb/ton
1st gear	890 lb/ton

WHEELS

Type FB/R 5.00 x 18 disc type

TYRES (RF or RFE type)

7.00 x 18

TYRE PRESSURES (RF only)

Front	35 lb/sq in.	(2.46 Kg/sq.cm.)
Rear	45 lb/sq in.	(3.16 Kg/sq.cm.)

BRAKES

Foot Hydraulic on all wheels
Hand Mechanical on rear wheels only

CAPACITIES

Engine lubrication system	
Cooling system	
Fuel tank	
Ki-gass fuel tank	
Fluid coupling	
Gearbox	
Transfer box	
Bevel boxes (4) - each	
Air cleaner (late type)	
Air cleaner (early type)	

Imperial	U. S. A.	Metric (litres)
2 gal	2½ gal	9.09
4 gal	5 gal	18.18
18 gal	21½ gal	81.81
⅓ pint	2/5 pints	0.18
8½ pints	10¼ pints	4.81
5 pints	6 pints	2.84
3 pints	3½ pints	1.70
3½ pints	4¼ pints	1.98
2½ pints	3 pints	1.42
4 pints	5 pints	2.54

STEERING

Type Worm and sector - 24 : 1 ratio
Front wheel toe-in 3/16-1/4 in. (4.76-6.35 mm)

SUSPENSION

Type Fully independent wishbone
Springs Coil
Shock absorbers Luvax, type P6/22

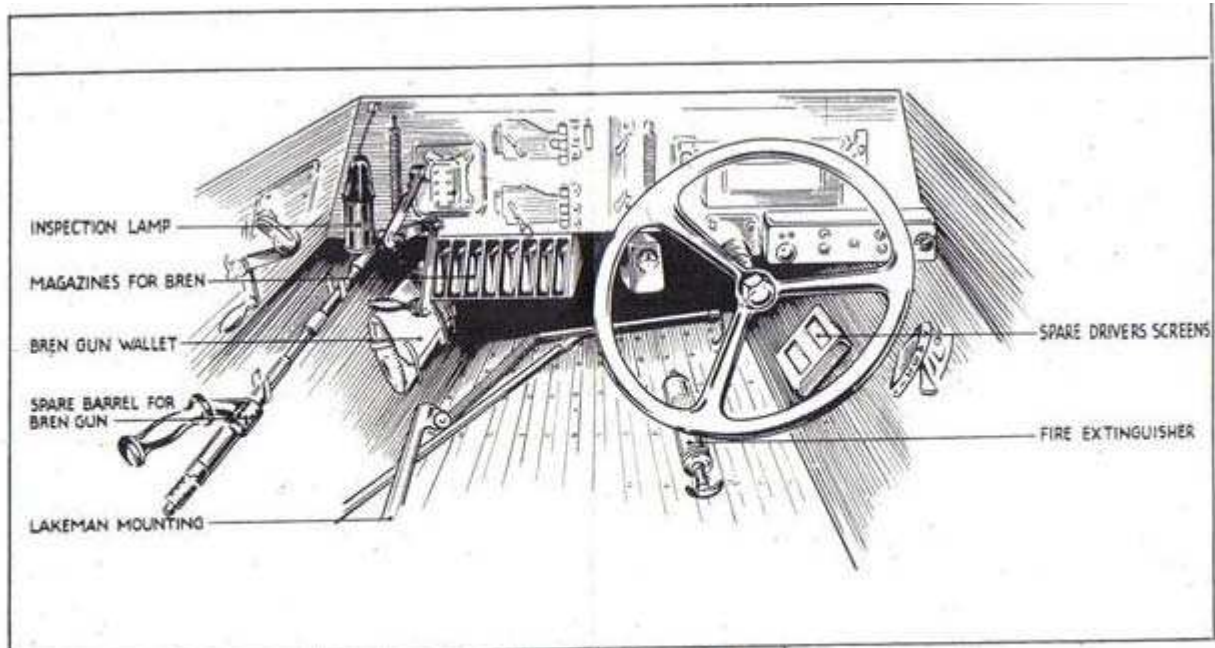

CAR , SCOUT, MK I^A TYPICAL FOR MK³ I & I²
STOWAGE SKETCH
INTERIOR - FRONT

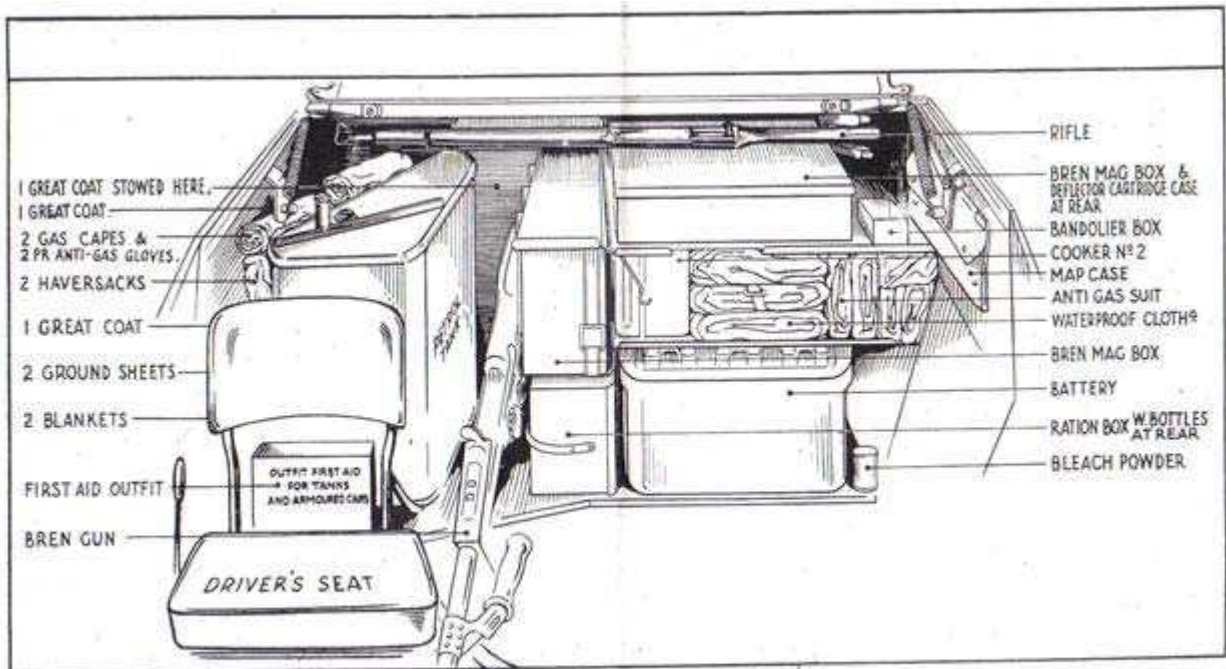

CAR , SCOUT, MK I^A TYPICAL FOR MK³ I & I²
STOWAGE SKETCH
INTERIOR - REAR

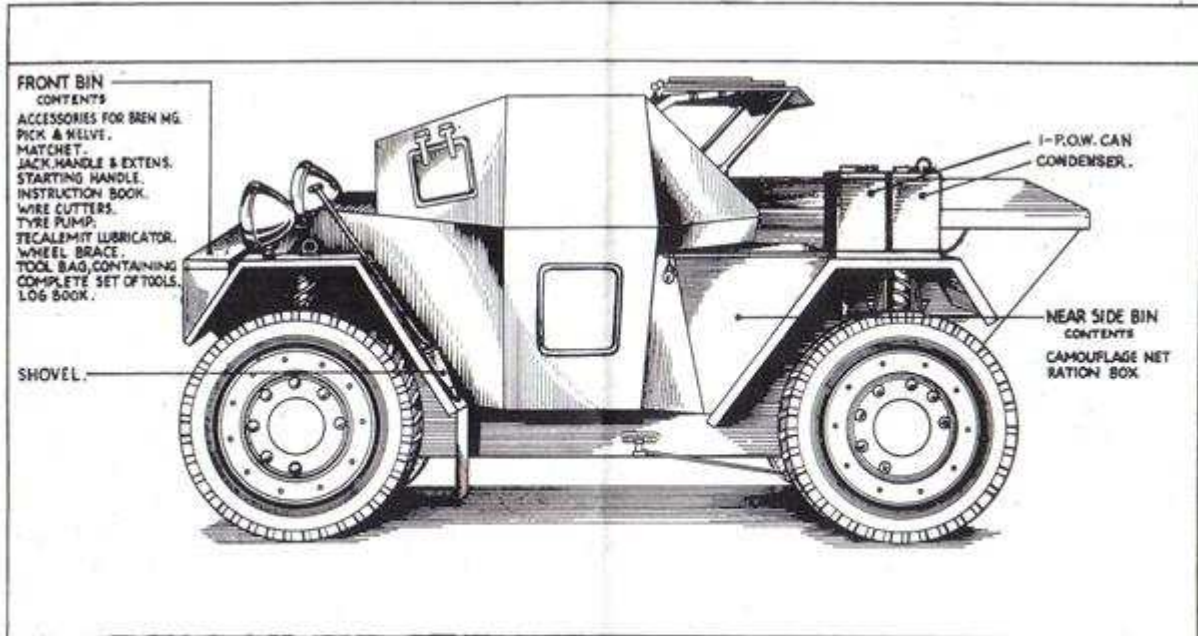

CAR, SCOUT, MK I^A, TYPICAL FOR MK¹ I.I.¹
STOWAGE SKETCH
EXTERIOR – NEARSIDE

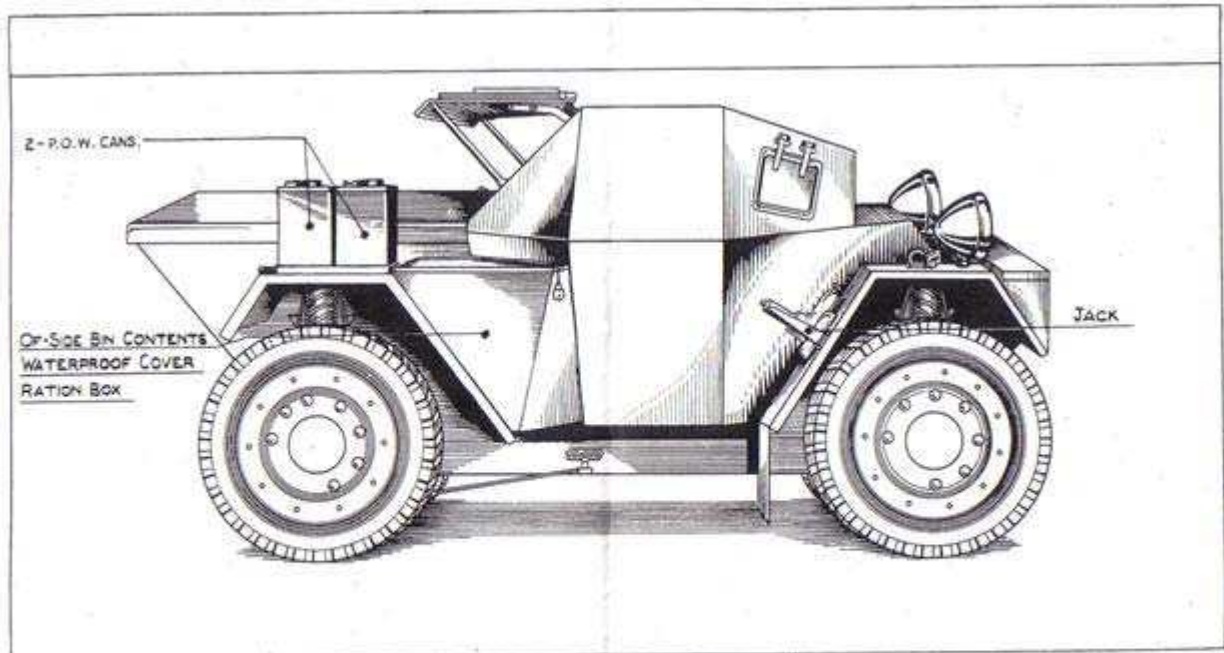

CAR, SCOUT, MK I^A, TYPICAL FOR MK¹ I.I.¹
STOWAGE SKETCH
EXTERIOR – OFFSIDE

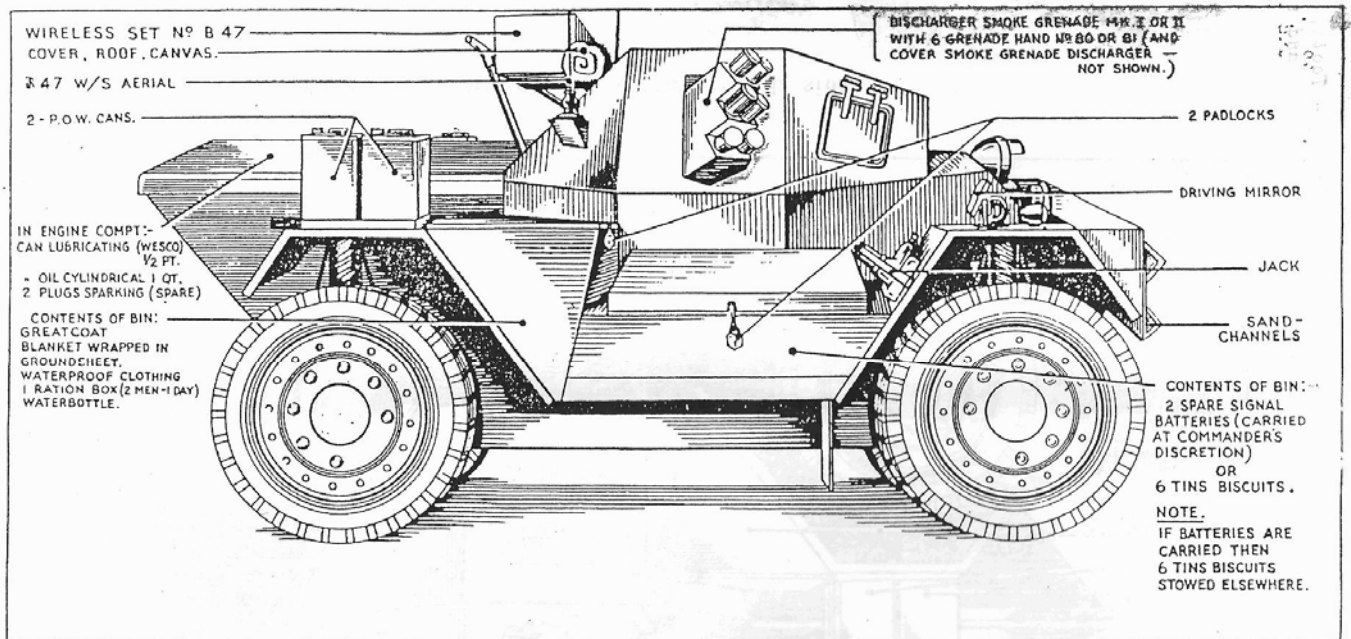

Exterior stowage of Mk 2 vehicle - R.H. side

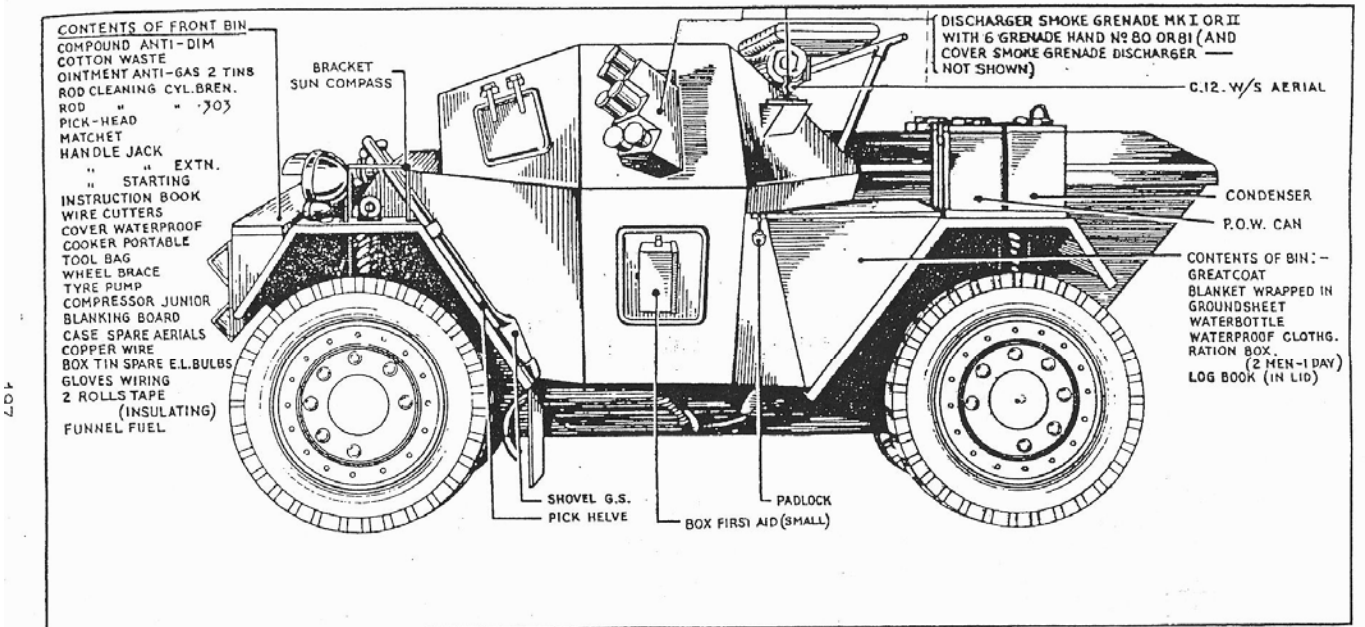

Exterior stowage of Mk 2 vehicle - L.H. side

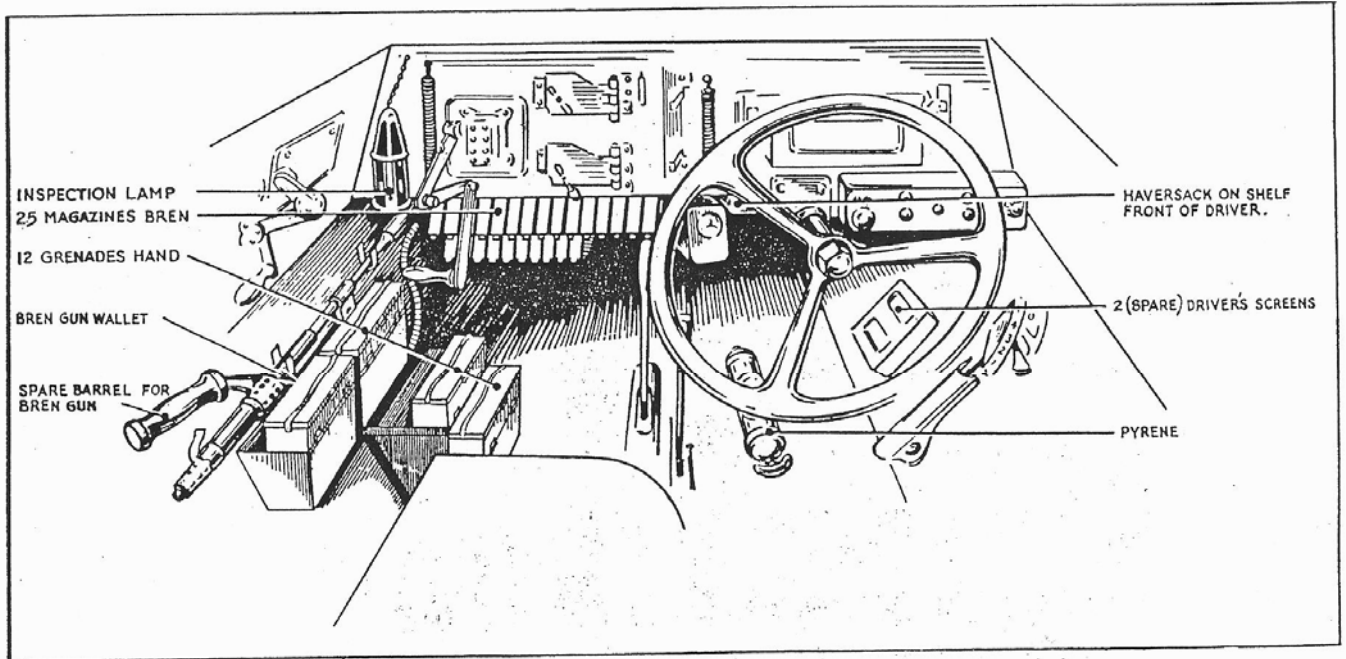

Interior stowage of Mk 2 vehicle - front

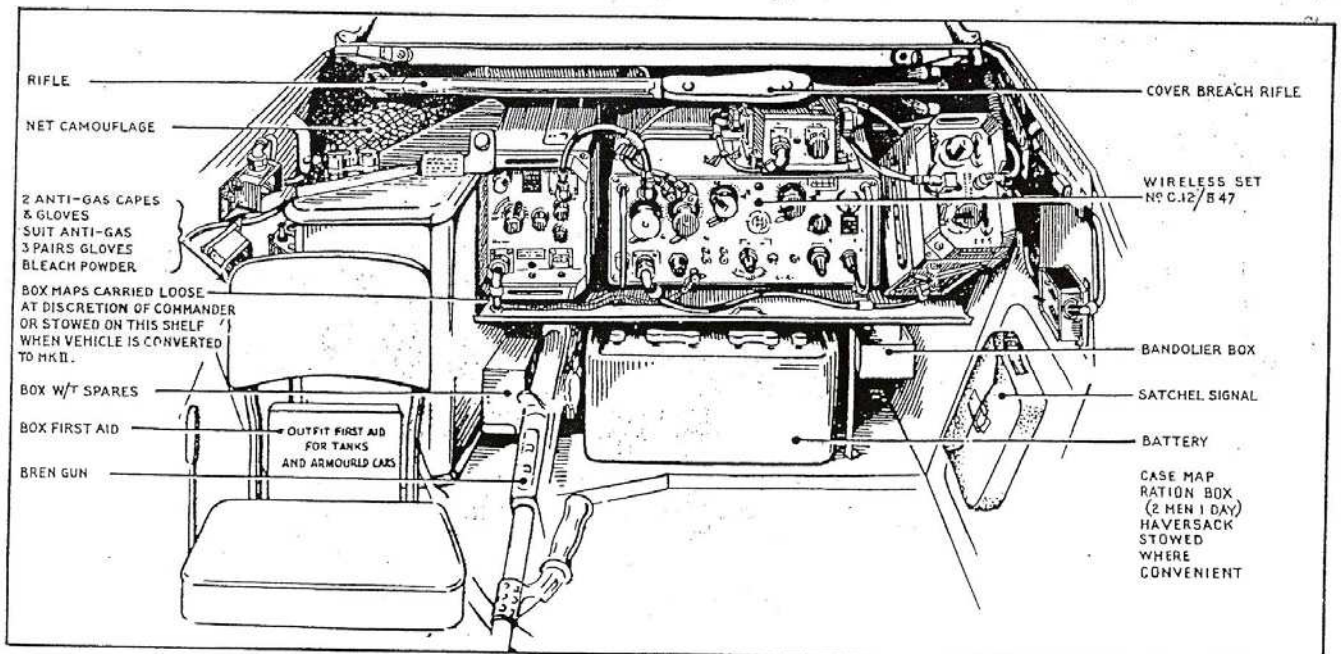

Interior stowage of Mk 2 vehicle - rear

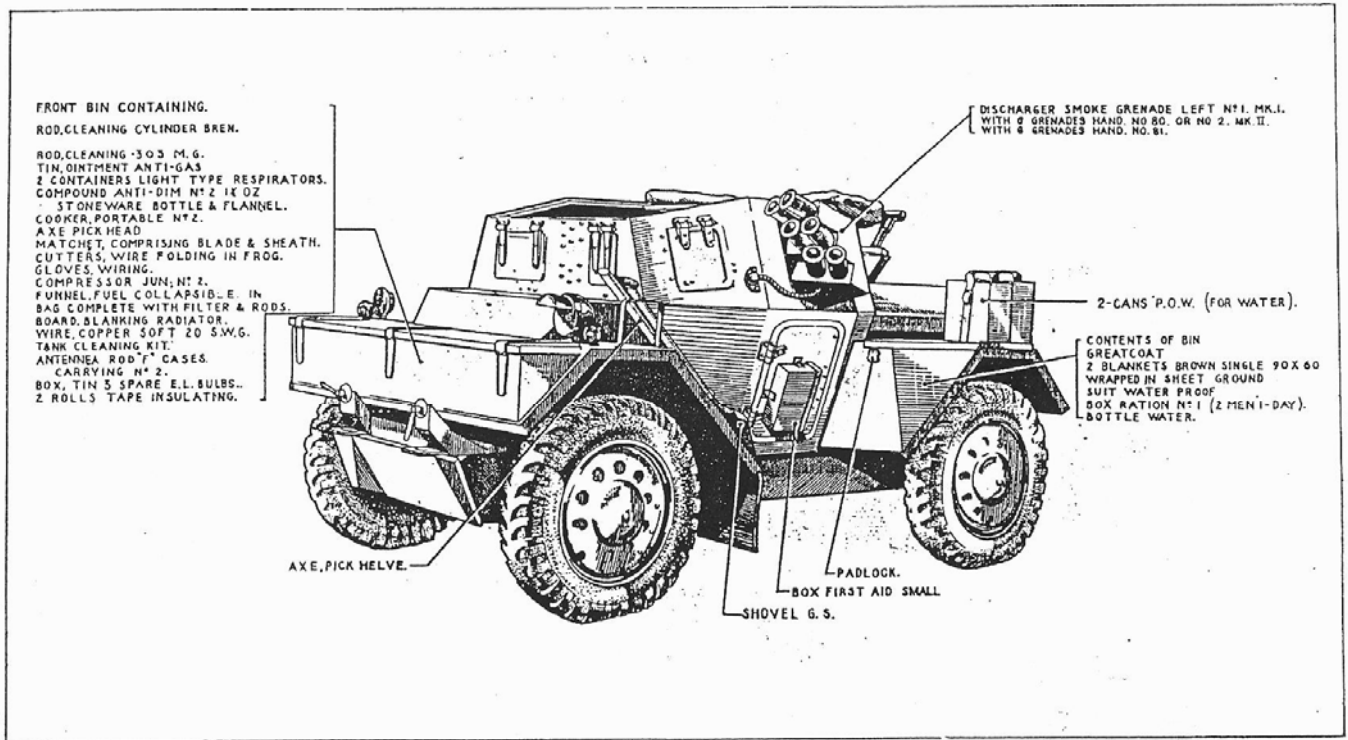

Exterior stowage of Mk 3 vehicle - L.H. side

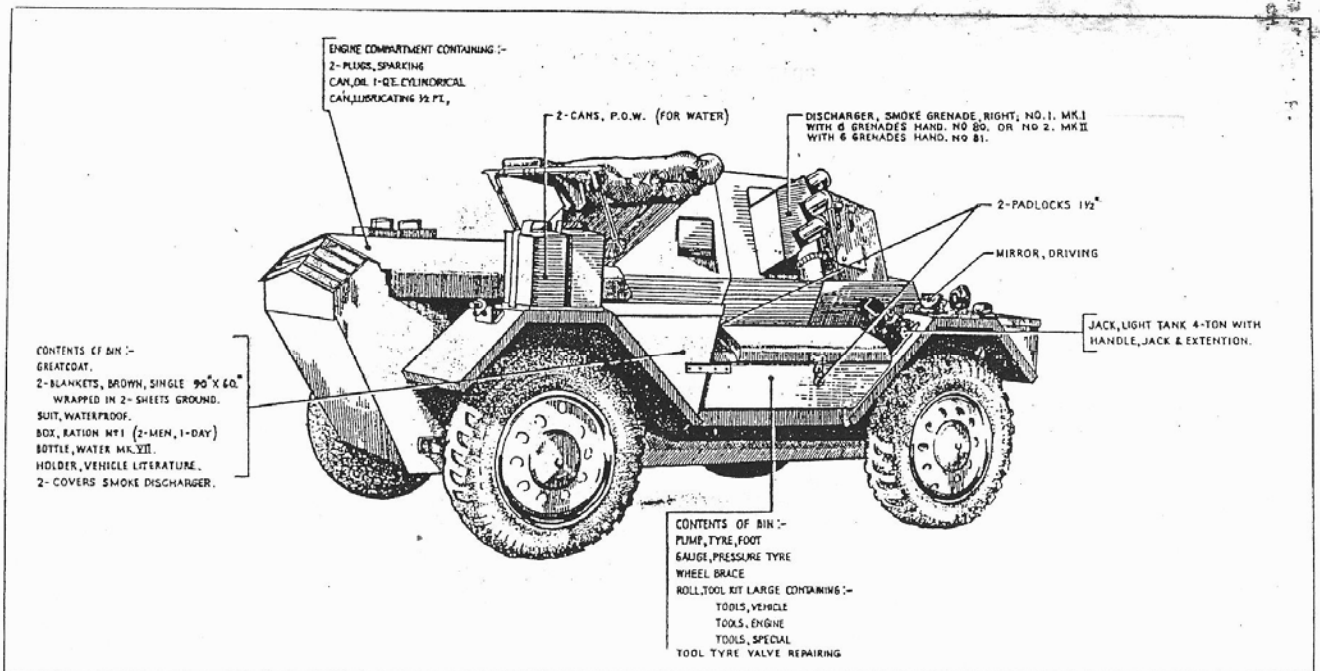

Exterior stowage of Mk 3 vehicle - R.H. side

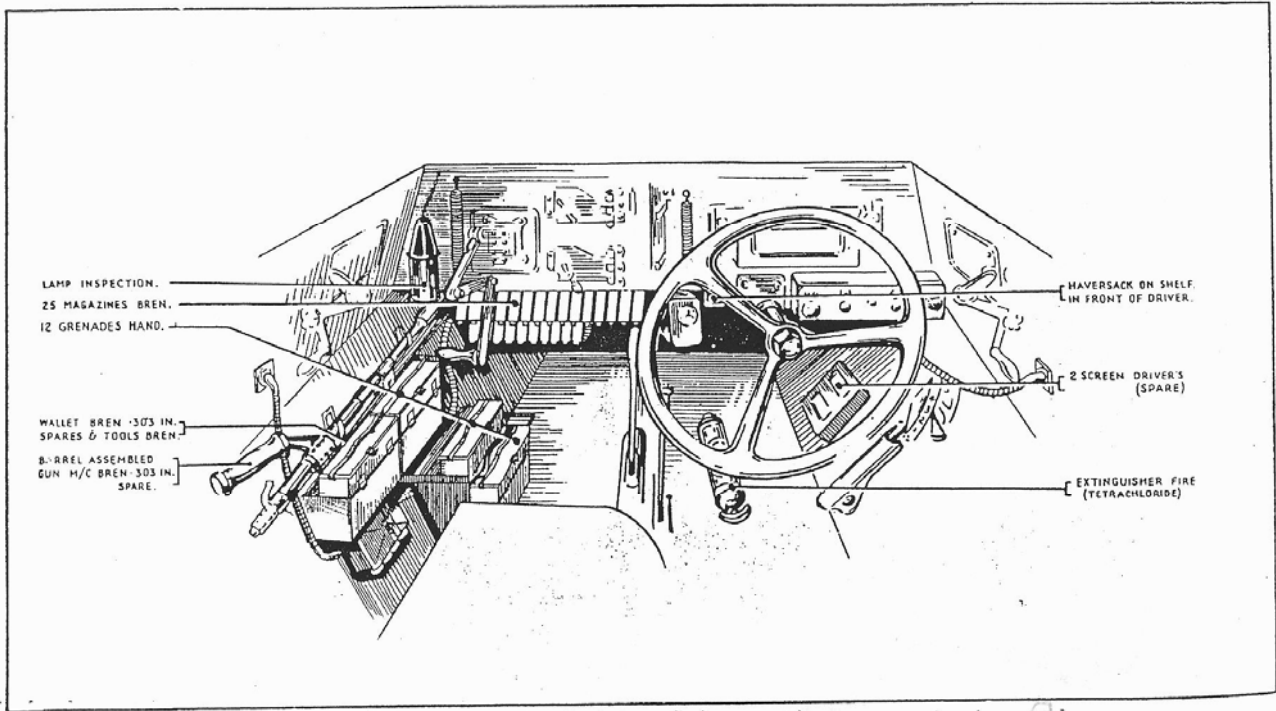

Interior stowage of Mk 3 vehicle - front

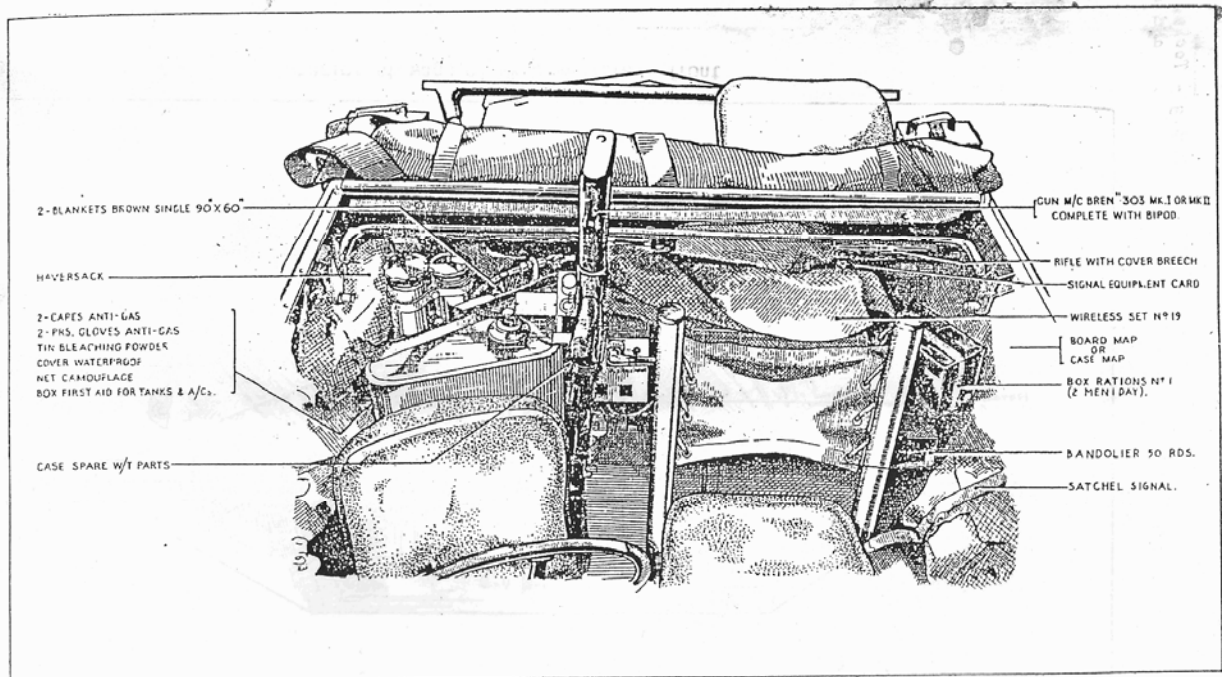

Chap. 3 - Tools, spares
 and stowage

Interior stowage of Mk 3 vehicle - rear